

# “SANMOTION F5” -Series Model Micro-step Driving 5-phase Stepping Driver

Shigehiro Kamada Masao Mizuguchi Tetsuji Takizawa Yasuyoshi Hamada

## 1. Introduction

Stepping systems are widely used as actuators for semiconductor manufacturing equipment, office automation equipment, and food machinery, with their reasonable system costs and their ease of open-loop control. SANYO DENKI developed and marketed new pentagon winding-compliant 5-phase stepping system in 2006. Currently, the market demands a driver with micro-step driving function installed in it for further noise reduction and vibration.

In response to the demand, SANYO DENKI newly developed “SANMOTION F5” -series model micro-step driving 5-phase stepping driver.

This report describes the overview and features.

## 2. Product Overview

Figure 1 shows the appearance of the new model.

We constructed the model of low on-resistance surface mount type FET for the power device aiming to release the heat to the heatsink. This suppressed heat generation and managed to limit the product height to 28 mm.

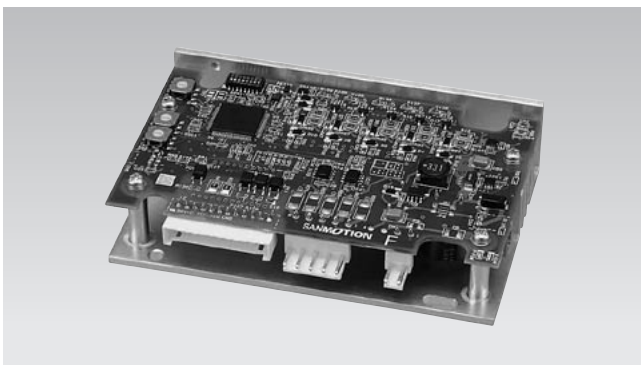

Fig. 1: Appearance

## 2.1 Specifications

Figure 2 shows the dimensional outline drawing and table1 shows the specifications.

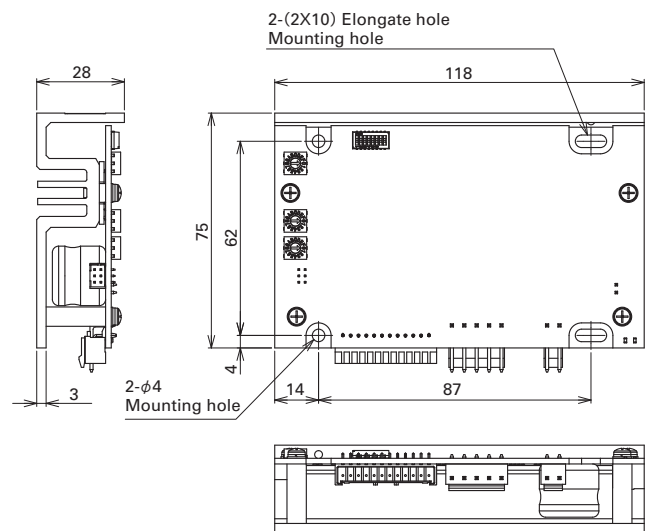

Fig. 2: Dimensional outline drawing

Table 1: Specifications

Model number		F5PAE140P100	
Basic specifications	Main circuit power	DC 24/48 V ± 10%	
	Main circuit power current	3 A	
	Environment	Effective Standard	EN61800-5-1, UL508C
		Operating Ambient Temperature	0 ~ +50°C
		Storage Temperature	-20 ~ +70°C
		Operating Ambient Humidity	35 to 85% RH (no condensation)
		Storage Humidity	10 to 90% RH (no condensation)
		Operating Altitude	ASL 1,000m or less
		Vibration	5m/s <sup>2</sup> Frequency range 10 to 55 Hz, 2 hours in the X, Y, Z direction
		Impact	20m/s <sup>2</sup>
		Dielectric strength	No errors when 0.5 kV AC is applied between the power supply terminal and the housing for one minute
		Insulation resistance	10 MΩ or more between the power supply terminal and the housing with a 500 V DC
	Mass	230 g	
Compatible motor size	□28 mm ~ φ 86 mm		
Functions	Selection functions	Pulse input type (single input type/dual input type), low vibration mode (low vibration operation/micro step operation), resolution (2-phase mode/5-phase mode), output signal (phase origin monitor/alarm), operation current, step angle	
	Protection function	Overcurrent protection	
	LED indicator	Power monitor, alarm indication	
Input/output signal	Auto current-down cancelation input signal	Photocoupler input method, input resistance 330 Ω	
	Step angle selection input signal	Photocoupler input method, input resistance 330 Ω	
	Command pulse input signal	Photocoupler input method, input resistance 330 Ω , maximum input frequency 400 k pulse/s	
	Power down input signal	Photocoupler input method, input resistance 330 Ω	
	Phase origin monitor output signal / alarm output signal	Open collector output by photocoupler	

### 3. Features

#### 3.1 Small-sized and light-weighted

Downsizing and weight saving for the new model have been achieved with miniature parts and optimized heatsink fin shape (new model-to-DC 48 V-compliant model volume ratio is 45%, the mass has been reduced by 8% of the one of DC 48 V-compliant model.).

Figure 3 shows new model-to-convention model volume comparison.

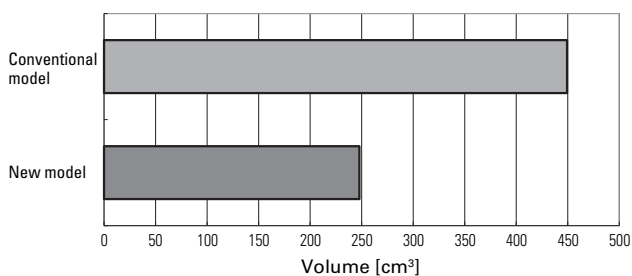

Fig. 3: Volume comparison

#### 3.2 Low-vibration

Micro-step driving function is a method to divide motor primary stepping angle by controlling current at each phase in incremental steps without using mechanical devices. This is fundamental function to reduce machine vibration and for subtle positioning. The new model achieved to create ideal motor current by detecting and controlling winding current at each phase controlling in addition to install this function. This greatly suppressed velocity fluctuation compared to the conventional model with micro-step driving function installed in it.

Figure 4 shows velocity fluctuation characteristics compared to the conventional model.

Stepping motor has a disadvantage that the vibration caused by step-driving at low velocity increases. This vibration becomes greater especially when command resolution is low. The new model installs low-vibration mode function to modify the vibration issue. This function enables the driver to smoothly operate with micro-step

driving control, without any changes to velocity and resolution setting for the host controller, even when coarse division number, such as 1 (full-step) or 2 (half-step), is set.

Figure 5 shows the effect of the low-vibration mode when division number of motor primary stepping angle is 1.

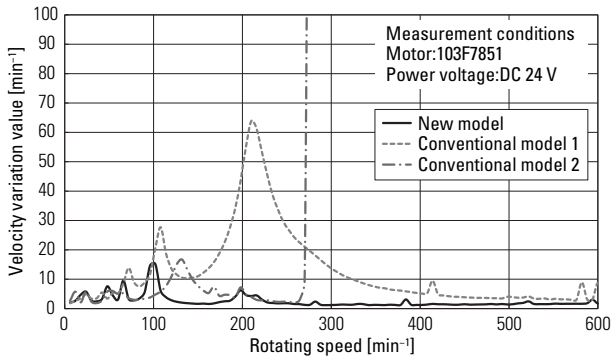

Fig. 4: Velocity fluctuation characteristics

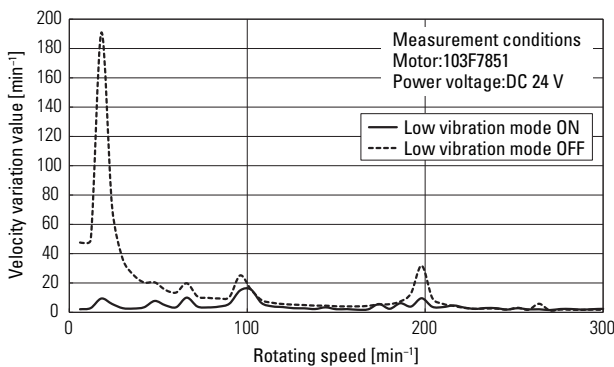

Fig. 5: Effects of low vibration mode

### 3.3 Improved positioning accuracy

The new model detects motor winding current at each phase and performs high accuracy current control. This could greatly reduce the static angle error compared to the conventional model.

Figure 6 shows the static angle error comparison.

Two division numbers for stepping motor primary stepping angle can be selected from 16 numbers (1 to 250) with the rotary switch. Switching the division number with externally input signal has been available.

We also enable the new model to operate with the division number conforming to 1.8°, 2-phase motor primary stepping angle, aiming for substituting 2-phase stepping motor by the new model.

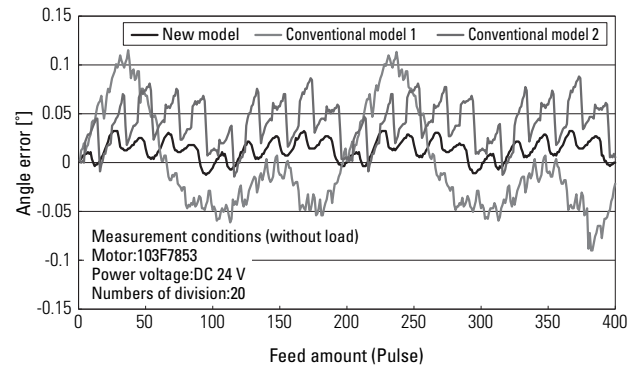

Fig. 6: Static angle error

### 3.4 Enhanced torque in high-velocity range

The torque in high-velocity range in this model has been enhanced by supporting DC 48 V main circuit power supply as well as DC 24 V. This can increase the velocity of equipments.

Figure 7 shows frequency-torque characteristic comparing main circuit power supply voltage DC 24 V with DC 48 V.

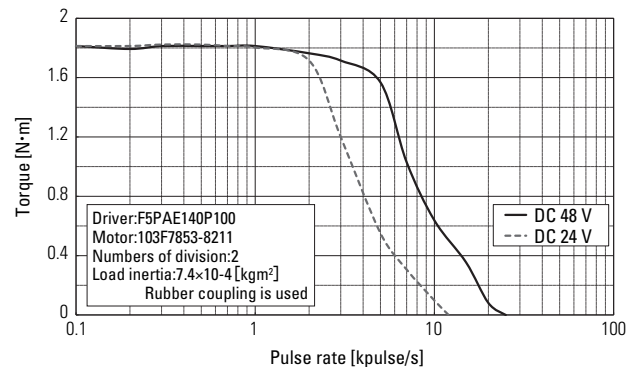

Fig. 7: Frequency – torque characteristics

### 3.5 Protective features installed

The new model installs functions to monitor the current running to the main circuit, and protect the driver from overcurrent due to short-circuit between motors or power line grounding fault.

Regeneration controlling circuit to suppress regenerative voltage induced by rapid slowdown is also installed in the new model as standard. A regenerative resistor is also available as an option. With these protecting functions, the reliability of the equipments can be ensured.

## 4. Conclusion

---

We believe “SANMOTION F5” -series model micro-step driving 5-phase stepping driver has been developed as a high performance product with superior cost performance. We intend to develop smaller-sized and more high-performance driver to expand 5-phase stepping system aiming for contributing to improve performance in customer equipments.



### **Shigehiro Kamada**

Joined Sanyo Denki in 1986.  
Servo Systems Division, 2nd Design Dept.  
Previously worked on the design and development of controllers. Now works on the design and development of stepping drivers.



### **Masao Mizuguchi**

Joined Sanyo Denki in 1998.  
Servo Systems Division, 2nd Design Dept.  
Worked on the design and development of stepping drivers.



### **Tetsuji Takizawa**

Joined Sanyo Denki in 1996.  
Servo Systems Division, 2nd Design Dept.  
Previously worked on the design and development of controllers. Now works on the design and development of stepping drivers.



### **Yasuyoshi Hamada**

Joined Sanyo Denki in 2009.  
Servo Systems Division, 2nd Design Dept.  
Worked on the design and development of stepping drivers.